



MARAD, ACHIEVING CRITICAL MASS CONFERENCE | BWI MARRIOTT HOTEL JULY 22 & 23, .2019

Latest results in evidence-driven evolution

Towards autonomousshipping

Eero Lehtovaara, Head of Regulatory Affairs, ABB Marine & Ports



ABB Marine & Ports at a glance

Part of ABB Group



Group
revenue >\$34,0bn

Innovations



» Hybrid and Fully Electric Solutions



» Automated and Unmanned



» Digital

Customer segments



- » Passenger ships
- » Oil & Gas
- » Merchant ships
- » Special ships
- » Container terminals

Global footprint



26 countries

Marine Solutions



- » Propulsion Solutions
- » Electric Solutions
- » Digital Solutions
- » Services

Ports Solutions



- » Crane Automation
- » OCR and Process Automation
- » Port Electrification
- » Services

How to cope with disruption?

Foundations have changed. Operations will change.

ELECTRIC

Decarbonization of Shipping

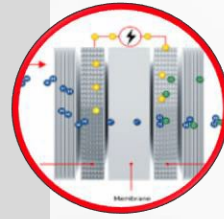

DIGITAL

Machine learning and augmented reality.



CONNECTED

Role of the human in the loop will be different

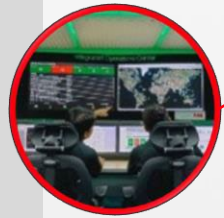

Simplicity, Efficiency, Safety

Intelligence

Component level data



We do not want to change

1850

1900

1950

2000

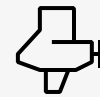

Power train

Navigation
and
automation



Maintenance



Roadmap

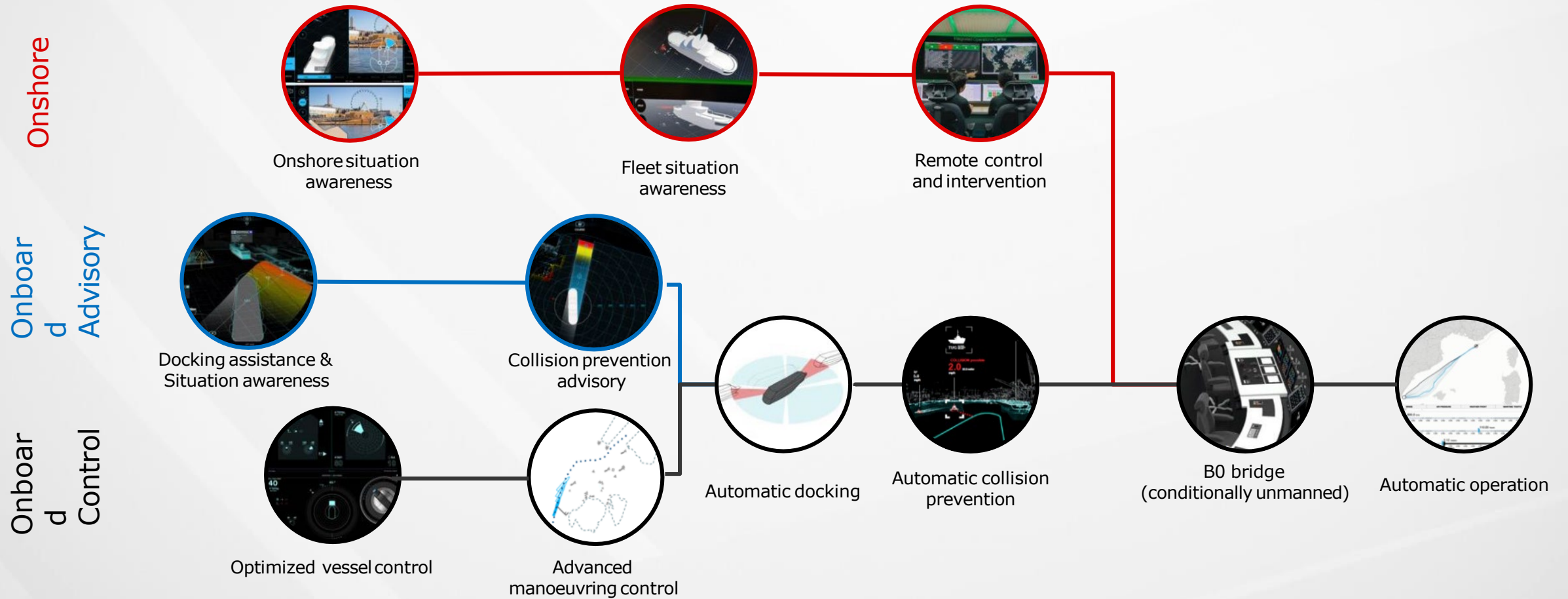

Electric. Digital. Connected.

Digital

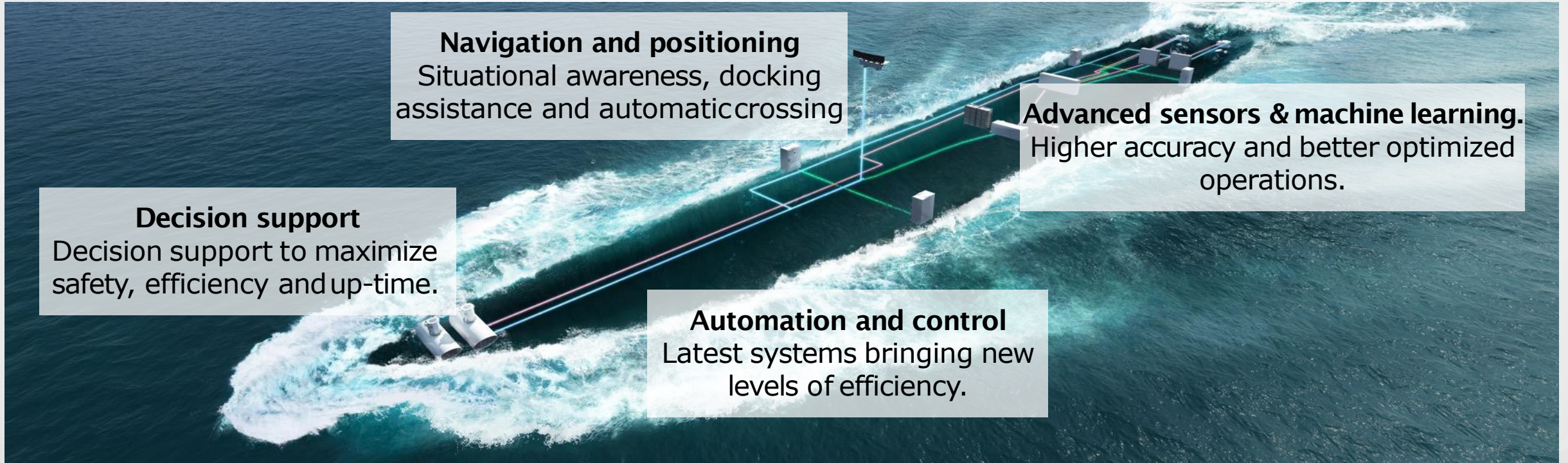

Navigation and positioning
Situational awareness, docking assistance and automatic crossing

Advanced sensors & machine learning.
Higher accuracy and better optimized operations.

Decision support
Decision support to maximize safety, efficiency and up-time.

Automation and control
Latest systems bringing new levels of efficiency.

Digitalization is changing the way ships are designed and operated

Maximizing the full potential in shipping

Electric.



Digital.



Connected.



... something we know a whole lot about.

Market will develop gradually

Decisive factors

Legislation

Global conventions demand physical presence:
- United Nations Convention on the Law of the Sea
- Safety of Life at Sea
National administrations granting exemptions

Business Models

Customer value
Revenue
Cost
Risk and Liability

Technology

“Autonomous and remote-controlled ships shall be as safe as conventional ships of the same type”
Technology will develop exponentially.

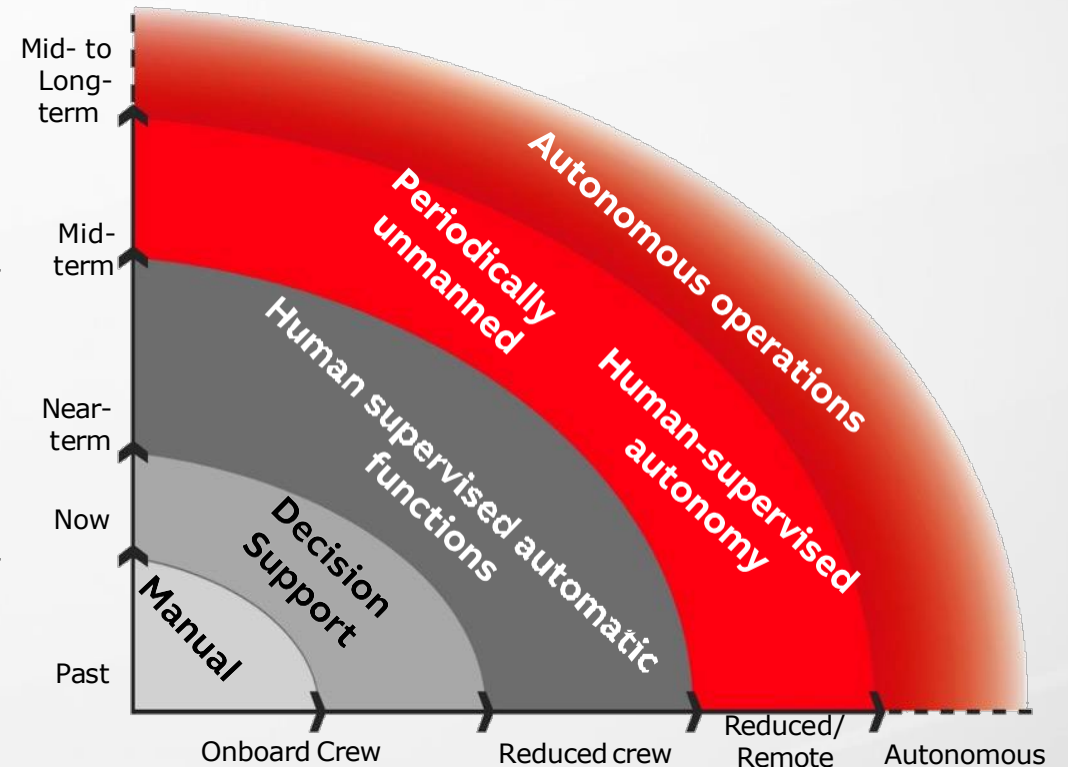

Market will develop gradually

Local traffic



Autonom

Innovations applied differently

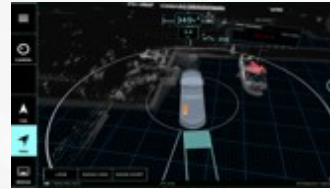

Situational awareness



Motion control



Collision avoidance & Object recognition



Electric and self-healing machinery

International traffic

Assistin



Same technology – different applications

ABB Ability™ Marine Pilot Family

Platform for next generation ship control

Onshore

ABB Ability™ Marine Pilot

Onboard

ABB Ability™ Marine Pilot Vision -Platform

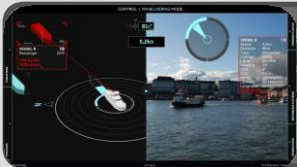

Lookout module

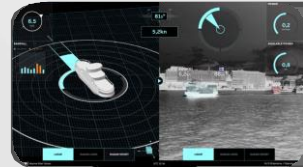

Weather module

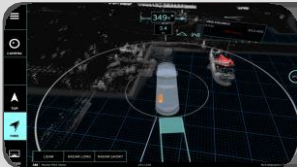

Docking module



Fairway module

Integration to sensors



ABB Ability™ Marine Pilot Control -Platform



Joystick, DP, Autopilot

ABB Ability™ Marine Pilot Control

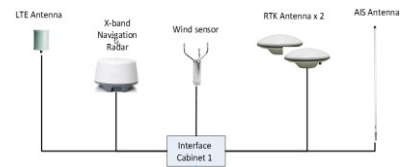
A simpler way of running your ship



ABB Ability™ Marine Pilot Vision

Increasing Situational Awareness by sensor fusion

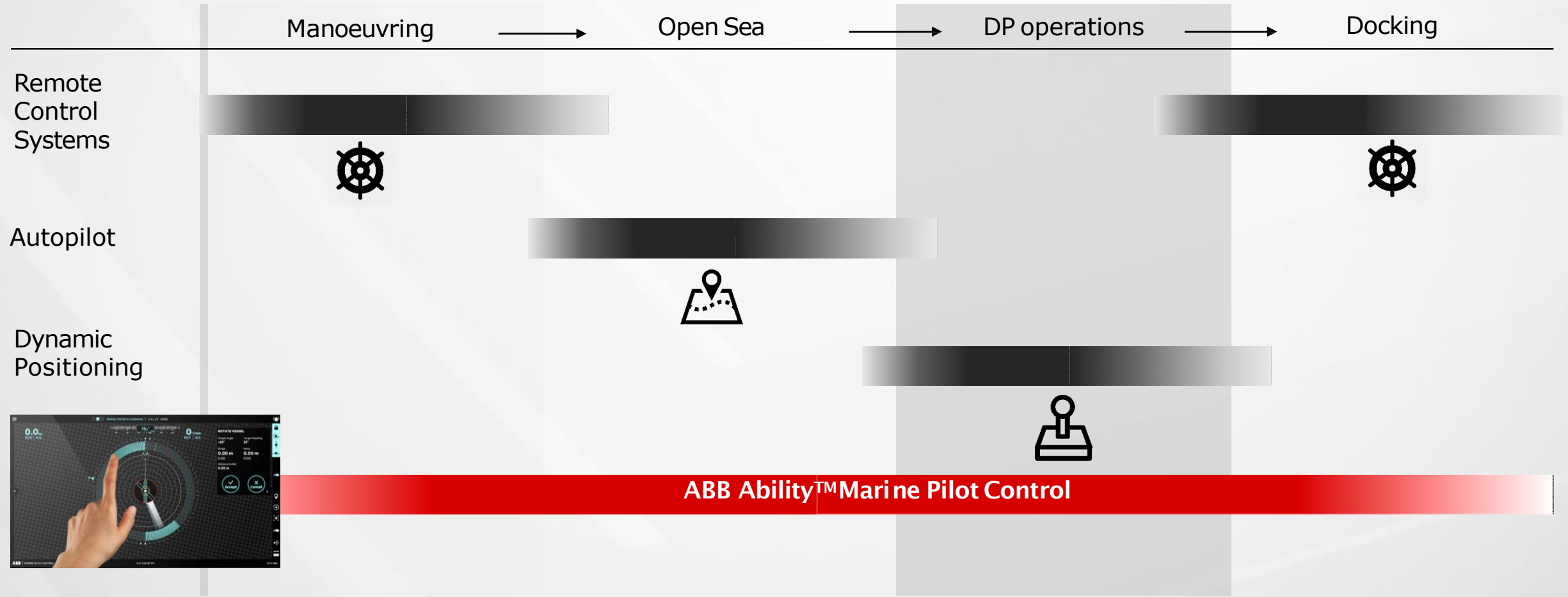
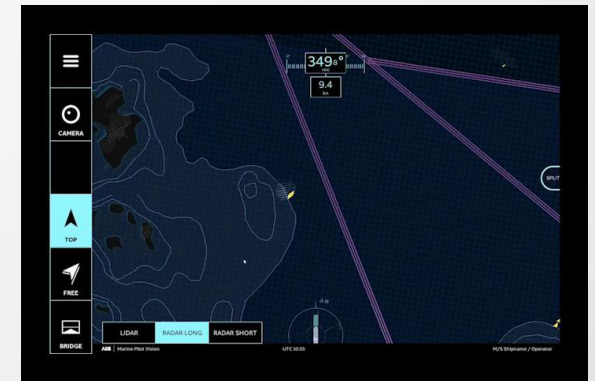
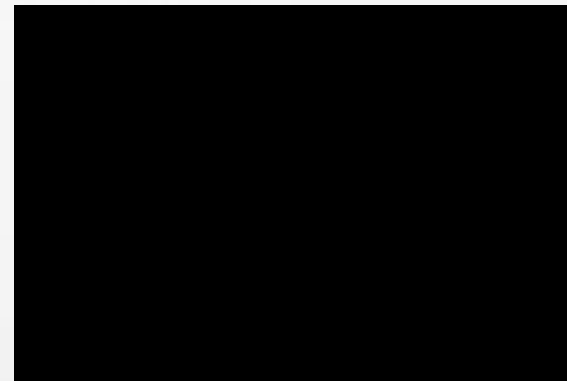
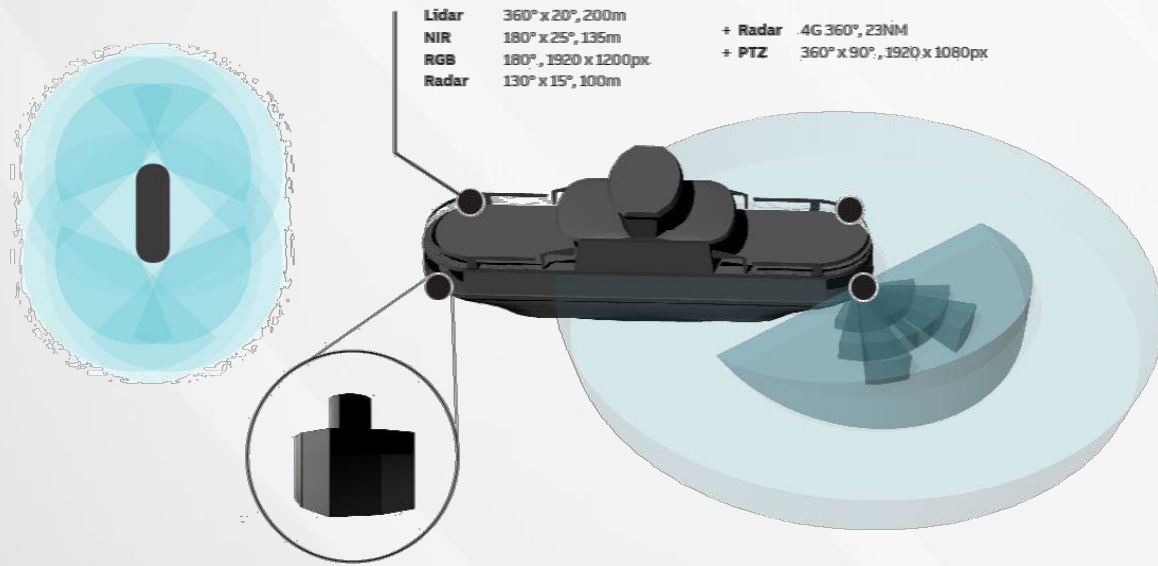

NUP

FREE

0

0
8
:
0
1
:
3
6

CAMERA



08:11:07

RGB

07-03-2019

CAMERA

 TOP
 FREE
 BRIDGE

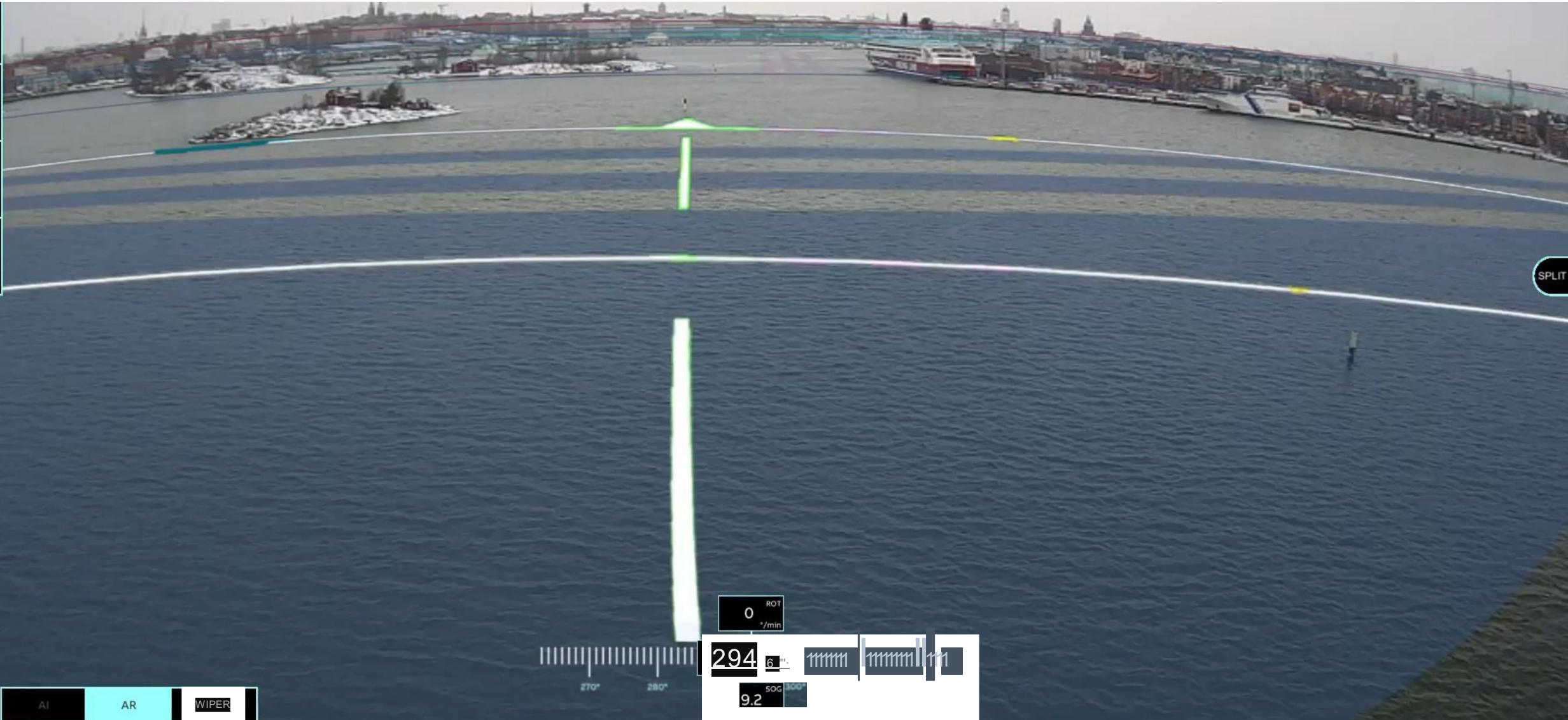

SPLIT

AI AR WIPER
 0 ROT $^{\circ}/\text{min}$
 294 6.1
 9.2 SOG 300
 270° 280°

Marine Pilot product family

Deployment

Silja Serenade

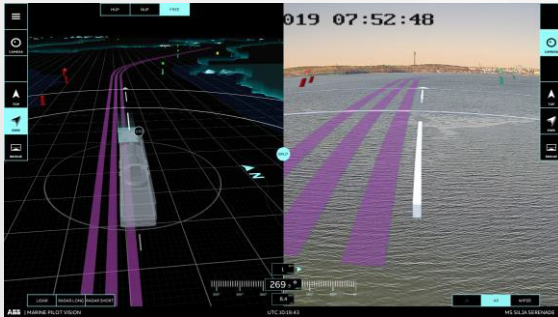

Finlandia



RCYC Azora



Suomenlinna II



Commercial references for next generation vessel control and situational awareness are being delivered

Autonomous ≠ Unmanned

“

It is our intent to provide solutions to the current and near future fleet where technology is used alongside competent ship's officers

”



ABB