

ABBREVIATIONS

ABL - ABOVE BASELINE	MIN - MINIMUM
ABT - ABOUT	MLD - MOLDED
B - BRACKET	N&F - NEAR SIDE & FAR SIDE
BHD - BULKHEAD	NS - NEAR SIDE
BKT - BRACKET	NT - NON-TIGHT
BTM - BOTTOM	OA - OVERALL
C - FULL COLLAR	OPNG - OPENING
C/F - CUT FROM...	OT - OIL-TIGHT
CHK - CHOCK	OUTBD - OUTBOARD
CL - CENTERLINE	PLATF - PLATFORM
CLR - CLEAR	PLT - PLATE
CMG - COAMING	P/S - PORT & STARBOARD
CTR - CENTER	REF - REFERENCE
CTRD - CENTERED	RHS - STRUCTURAL TUBE
DBLR - DOUBLER	RECTANGULAR HOLLOW SECTION
DK - DECK	S - SNIPE SHORT
FB - FLAT BAR	SHS - STRUCTURAL TUBE
FCPLT - FACEPLATE	SQUARE HOLLOW SECTION
FLG(D) - FLANGE(D)	SIM - SIMILAR
FR - FRAME	SPCG - SPACING
FS - FAR SIDE	STBD - STARBOARD
FWD - FORWARD	STD - STANDARD
GDR - GIRDER	STFNR - STIFFENER
HDR - HEADER	T&B - TOP & BOTTOM
HP - HOLLAND PROFILE (BULD FLAT)	TRANSV - TRANSVERSE
IB - INNER BOTTOM	TYP - TYPICAL
INBD - INBOARD	VL - VERTICAL LADDER
INTRMDT - INTERMEDIATE	W - WELDED CONNECTION
IWO - IN WAY OF	W/ - WITH
KNU - KNUCKLE	W/O - WITHOUT
L - LUG	WT - WATER-TIGHT
L - STEEL ANGLE	WTB - WATER-TIGHT BHD
LG - LONG	-II- - DITTO (SAME AS...)
LKG - LOOKING	
LONGL - LONGITUDINAL	

GENERAL NOTES

- EXCEPT WHERE OTHERWISE NOTED, ALL STEEL IS TO BE MILD STEEL, ABS GRADE A.
- ALL MATERIAL, WELDING, FABRICATION AND WORKMANSHIP IS TO BE IN ACCORDANCE WITH APPLICABLE ABS RULES.
- DIMENSIONS IN MILLIMETERS EXCEPT WHERE OTHERWISE NOTED.
- PROVIDE RELIEF CUTS AS SHOWN IN THE TABLE BELOW. IF NONE IS SHOWN ON THE DETAIL, IT IS ASSUMED TO HAVE THE 10x10 CORNER SNIPE AND IS TO BE FILLED WITH WELD. SCALLOPS SHALL HAVE RADII AS SHOWN IN THE TABLE BELOW UNLESS NOTED OTHERWISE.
- FOR LONGITUDINAL AND TRANSVERSE SCANTLINGS NOT SHOWN ON THIS DRAWING, SEE REFERENCE DRAWINGS 1 AND 4.
- SCANTLINGS AND PANEL STIFFENER ARRANGEMENTS SHOWN ON THIS DRAWING MAY BE MODIFIED ACCORDING TO FURTHER DESIGN DEVELOPMENT. THE DETAILS SHOWN IN THIS DRAWING REPRESENT THE RESULTS OF A GENERAL APPLICATION OF ABS RULES AND A COARSE MESH FINITE ELEMENT ANALYSIS. INCREASES IN LOCAL LOADING DUE TO HEAVY EQUIPMENT OR MACHINERY HAVE NOT GENERALLY BEEN ACCOUNTED FOR AND SIGNIFICANT ADDITIONAL ANALYSIS AND DESIGN IS REQUIRED FOR DETAILED DESIGN AND FINAL CONSTRUCTION DRAWINGS.
- OPENINGS SHOWN ARE FOR ACCESS, TRUNKS, PANEL LIGHTENING AND SOME VENTILATION; NO CABLE OR PIPE OPENINGS HAVE BEEN SHOWN. DECK AND BHD OPENING SIZES ARE APPROXIMATE AND MAY BE MODIFIED AS REQ'D TO SUIT FINAL DEVELOPMENT.
- OPENINGS IN THE MAIN DECK TO HAVE A MINIMUM CORNER RADIUS OF 0.125 TIMES THE WIDTH OF THE OPENING, BUT NEED NOT EXCEED A RADIUS OF 600mm. (THIS DETAIL NOT SHOWN IN DRAWINGS)
- OPENINGS IN DECKS, OTHER THAN THE MAIN DECK, TO HAVE A MINIMUM CORNER RADIUS OF 0.09375 TIMES THE WIDTH OF THE OPENING, BUT NEED NOT EXCEED A RADIUS OF 450 mm. (THIS DETAIL NOT SHOWN IN DRAWINGS)

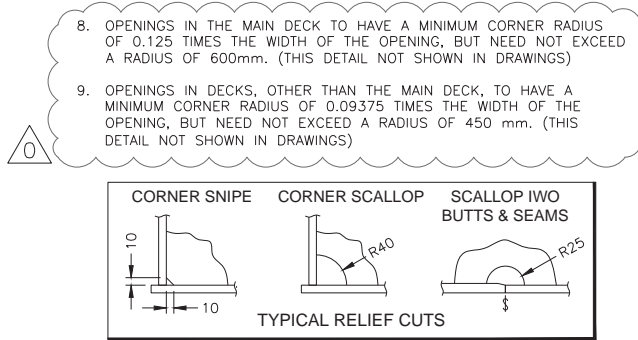

RESERVATIONS

- STRUCTURE AFT OF FR. 58.
- FOREPEAK AND BOW STRUCTURE PENDING DEVELOPMENT.
- 4TH DK & IB STRUCTURE AFT OF FR. 90 (IWO ENGINE ROOMS)

REVISIONS

No.	DESCRIPTION	BY/DATE/APPD
-	INITIAL ISSUE	MDS 02/28/17 EVR
0	CORRECTION OF ABS COMMENTS	CPB 01/11/17 EVR

REFERENCES

No.	TITLE	DWG or DOC No.
1	MIDSHIP SECTION	2015-017-03-11
2	SHELL EXPANSION	2015-017-03-41
3	DECKHOUSE SCANTLINGS	2015-017-03-43
4	TYP TRANSVERSE BHD	2015-017-03-44
5	-	-

HEC Herbert Engineering Corp.
Naval Architects San Francisco Glasgow
Marine Engineers Annapolis Shanghai
Ocean Engineers www.herbert.com

DRWN: MDS	DATE: DEC 12, 2016	SCALE: 1:250 & AS NOTED
CHKD: EVR	APPD: EVR	ACADFILE: 150170342
PROJECT FILE: 2015-017-03 (NSMV ph3 Structure)		PLOTSCALE: ANSI D 1:1
ABS APPROVAL: -		

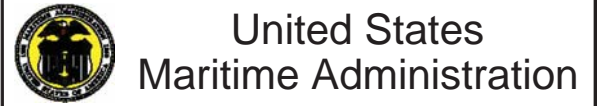

NSMV PHASE 3
HULL SCANTLINGS

OWNER APPVL: -	HEC DWG No.: 2015-017-03-42
DATE: -	
FILE: -	SHEET 1 OF 5 REV 0

HALF-SIZE PRINT

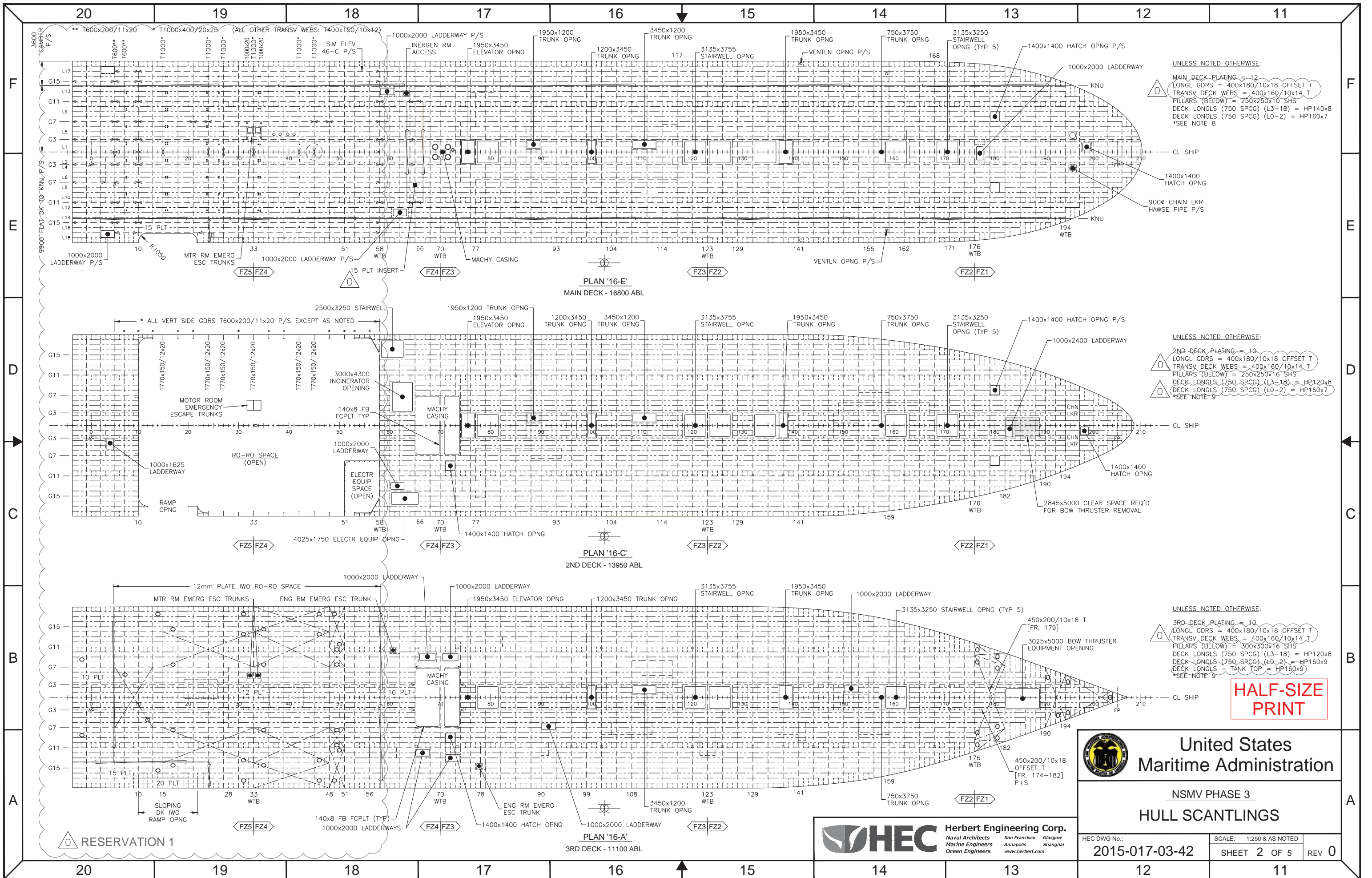

UNLESS NOTED OTHERWISE:
 MAIN DECK PLATING = 12
 LONGL GDRS = 400x180/10x18 OFFSET T
 TRANSV DECK WEBS = 400x160/10x14 T
 PILLARS (BELOW) = 250x250x16 SHS
 DECK LONGLS (750 SPCG) (L3-18) = HP140x8
 DECK LONGLS (750 SPCG) (L0-2) = HP160x7
 *SEE NOTE 8

UNLESS NOTED OTHERWISE:
 2ND DECK PLATING = 10
 LONGL GDRS = 400x180/10x18 OFFSET T
 TRANSV DECK WEBS = 400x160/10x14 T
 PILLARS (BELOW) = 250x250x16 SHS
 DECK LONGLS (750 SPCG) (L3-18) = HP120x8
 DECK LONGLS (750 SPCG) (L0-2) = HP160x7
 *SEE NOTE 9

UNLESS NOTED OTHERWISE:
 3RD DECK PLATING = 10
 LONGL GDRS = 400x180/10x18 OFFSET T
 TRANSV DECK WEBS = 400x160/10x14 T
 PILLARS (BELOW) = 300x300x16 SHS
 DECK LONGLS (750 SPCG) (L3-18) = HP120x8
 DECK LONGLS (750 SPCG) (L0-2) = HP160x9
 DECK LONGLS - TANK TOP = HP160x9
 *SEE NOTE 9

HALF-SIZE PRINT



United States Maritime Administration

NSMV PHASE 3
HULL SCANTLINGS

HEC **Herbert Engineering Corp.**
 Naval Architects Marine Engineers Ocean Engineers
 San Francisco Annapolis Shanghai
 Glasgow Shanghai www.herbert.com

HEC DWG No.:	SCALE: 1:250 & AS NOTED	REV 0
2015-017-03-42	SHEET 2 OF 5	

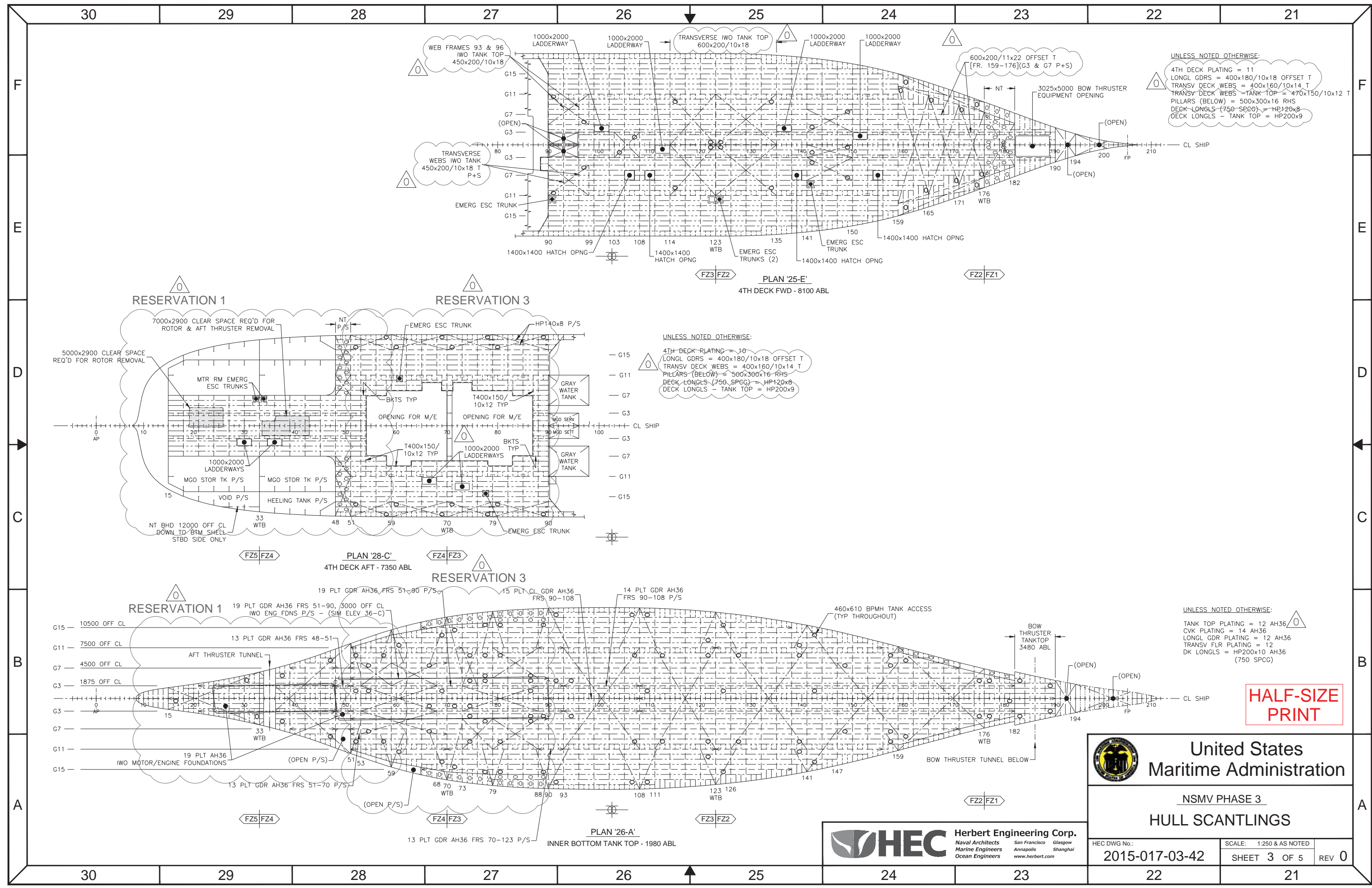

UNLESS NOTED OTHERWISE:
 4TH DECK PLATING = 11
 LONGL GDRS = 400x180/10x18 OFFSET T
 TRANSV DECK WEBS = 400x160/10x14 T
 TRANSV DECK WEBS - TANK TOP = 470x150/10x12 T
 PILLARS (BELOW) = 500x300x16 RHS
 DECK LONGLS (750 SPCG) = HP120x8
 DECK LONGLS - TANK TOP = HP200x9

UNLESS NOTED OTHERWISE:
 4TH DECK PLATING = 10
 LONGL GDRS = 400x180/10x18 OFFSET T
 TRANSV DECK WEBS = 400x160/10x14 T
 PILLARS (BELOW) = 500x300x16 RHS
 DECK LONGLS (750 SPCG) = HP120x8
 DECK LONGLS - TANK TOP = HP200x9

UNLESS NOTED OTHERWISE:
 TANK TOP PLATING = 12 AH36
 CVK PLATING = 14 AH36
 LONGL GDR PLATING = 12 AH36
 TRANSV FLR PLATING = 12
 DK LONGLS = HP200x10 AH36 (750 SPCG)

HALF-SIZE PRINT



United States Maritime Administration

NSMV PHASE 3
HULL SCANTLINGS

HEC Herbert Engineering Corp.
 Naval Architects Marine Engineers Ocean Engineers
 San Francisco Annapolis Shanghai
 Glasgow Shanghai www.herbert.com

HEC DWG No.: 2015-017-03-42
 SCALE: 1:250 & AS NOTED
 SHEET 3 OF 5 REV 0

30 29 28 27 26 25 24 23 22 21

F

F

E

E

D

D

C

C

B

B

A

A

30 29 28 27 26 25 24 23 22 21

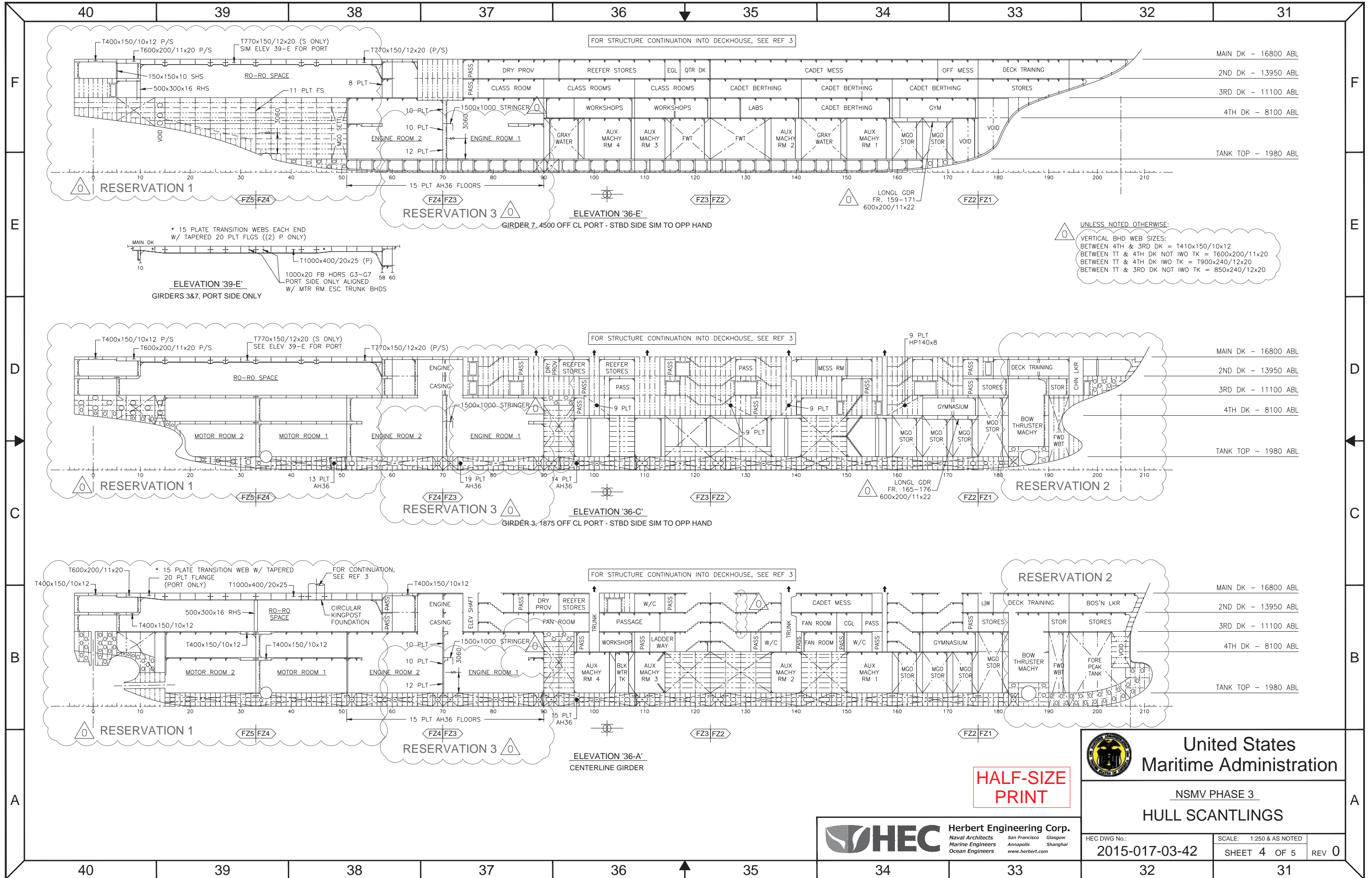

UNLESS NOTED OTHERWISE:
 VERTICAL BHD WEB SIZES:
 BETWEEN 4TH & 3RD DK = T410x150/10x12
 BETWEEN TT & 4TH DK NOT IWO TK = T600x200/11x20
 BETWEEN TT & 4TH DK IWO TK = T900x240/12x20
 BETWEEN TT & 3RD DK NOT IWO TK = 850x240/12x20

* 15 PLATE TRANSITION WEBS EACH END
 W/ TAPERED 20 PLT FLGS ((2) P ONLY)
 MAIN DK
 10
 T1000x400/20x25 (P)
 1000x20 FB HDRS G3-G7
 PORT SIDE ONLY ALIGNED
 W/ MTR RM ESC TRUNK BHDS
 ELEVATION '39-E'
 GIRDERS 3&7, PORT SIDE ONLY

* 15 PLATE TRANSITION WEB W/ TAPERED
 20 PLT FLANGE (PORT ONLY)
 T600x200/11x20
 T400x150/10x12
 500x300x16 RHS
 RO-RO SPACE
 CIRCULAR KINGPOST FOUNDATION
 FOR CONTINUATION, SEE REF 3
 T400x150/10x12
 T400x150/10x12
 MOTOR ROOM 2
 MOTOR ROOM 1
 ENGINE ROOM 2
 ENGINE ROOM 1
 10 PLT
 10 PLT
 12 PLT
 1500x1000 STRINGER
 3060
 15 PLT AH36 FLOORS
 15 PLT AH36
 ELEVATION '36-A'
 CENTERLINE GIRDER

United States Maritime Administration
 NSMV PHASE 3
 HULL SCANTLINGS

HALF-SIZE PRINT

HEC Herbert Engineering Corp.
 Naval Architects San Francisco Glasgow
 Marine Engineers Annapolis Shanghai
 Ocean Engineers www.herbert.com

HEC DWG No.: 2015-017-03-42
 SCALE: 1:250 & AS NOTED
 SHEET 4 OF 5
 REV 0

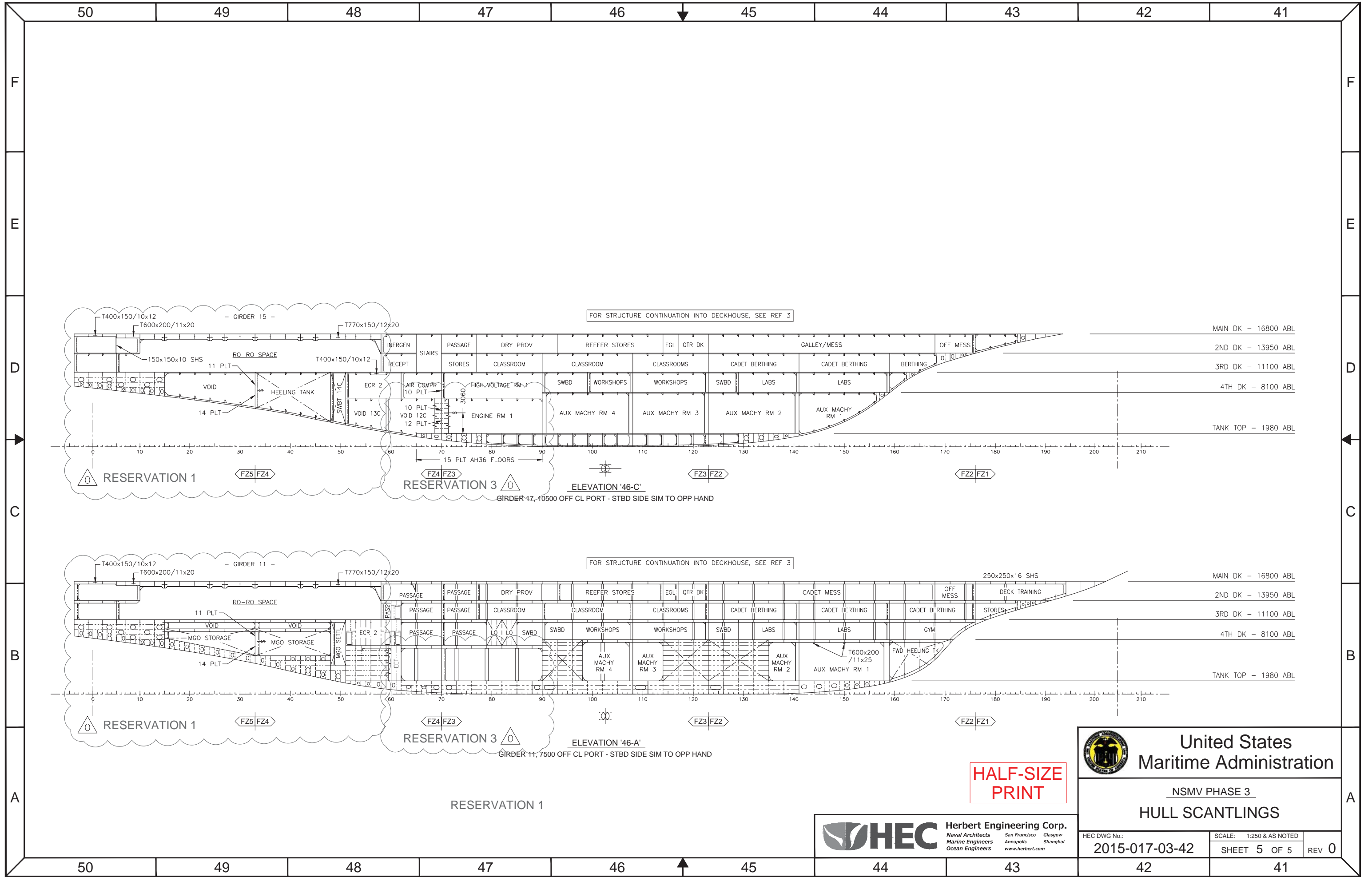

**HALF-SIZE
PRINT**



**United States
Maritime Administration**

**NSMV PHASE 3
HULL SCANTLINGS**

HEC **Herbert Engineering Corp.**
Naval Architects Marine Engineers Ocean Engineers
San Francisco Annapolis Shanghai
Glasgow Shanghai
www.herbert.com

HEC DWG No.: **2015-017-03-42**
SCALE: 1:250 & AS NOTED
SHEET **5** OF **5** REV **0**